

**DAVE'S
FASTENERS**

**'84
all new
edition**

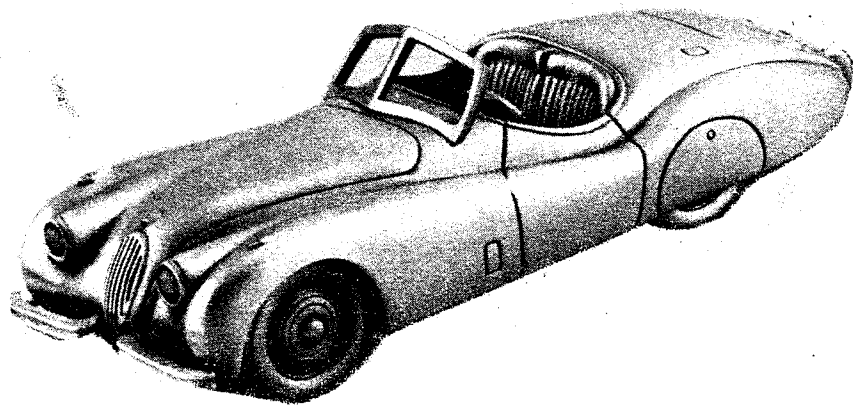

P.O. BOX 6645 , SAGINAW, mi 48608

DASH AND INSTRUMENT PANEL CLIPS

23412

CLIP –
DASH PAD CONNECTING



BUICK

All 1973

CHRYSLER 1974

85992

FASTENER – INTERIOR
TRIM PANELS

Anti-rattle Wedge Type



UNIVERSAL

86958

CLIP

Instrument Panel



OLDSMOBILE, All 1977-81



5730

FASTENER

Floor Mat, Front
Bronze Cap



UNIVERSAL

87518

BOLT RETAINER

- 6.3mm x 13mm outer diameter.
- Dash and instrument panels



GENERAL MOTORS, Cars 1978-82

7029

FASTENER

Grip Cap
Package Compartment Cardboard
Trim



UNIVERSAL

INTERIOR CLIPS & SCREWS

UPHOLSTERY CLIPS

- For Chrysler Products, Japanese and Mitsubishi models 1980-83



	COLOR
89239	Burgundy
89240	Off-White
89241	Light Blue
89243	Beige
89247	Black

INTERIOR TRIM SCREWS

89248

GENERAL MOTORS
Camaro, Firebird 1982-83
General use on GM cars

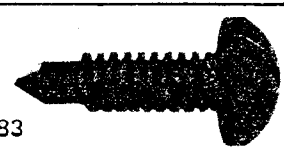

Color: Black

- Phillips oval head
- Unichrome plated
- Special countersunk washer

13740 No. 8 x 5/8"



86581 No. 10 x 3/4"
Oversize No. 8 head



13159 No. 8 x 3/4"



13739 No. 8 x 1

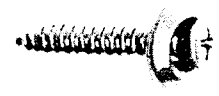

86582 No. 10 x 1"
Oversize No. 8 head

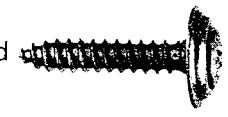

7748

Small WIRE CLIPS

Cushion spring clips to attach seat covers to cushions and seat bottoms



7749

Medium WIRE CLIPS



89249

ANCHOR-INTERIOR TRIM

- For spare tire cover/rear end panel retainer
- Use with screw No. 89248



GENERAL MOTORS

Firebird, Camaro 1982-83 Color: Off-white

22878

RETAINING SCREW

Sun Visor, Oversize Repair Screw



- Retains visor to mounting support
- Special oversize for stripped or worn holes
- Bright anti-corrosion Zinc Finish

GENERAL MOTORS

15320

SEMS TAPPING SCREW

- No. 8 x 11/32 special Phillips head type "A"; with free spring flat washer
- Chrome plated
- Designed to fasten panels on car interiors without tearing fabric



GENERAL MOTORS

DOOR TRIM FASTENERS

22689

CLIP – DOOR TRIM
PANEL MOULDING



DODGE Truck

1972-73

87515

CLIP – INSIDE DOOR
PANEL ATTACHING



- Impact resistant nylon

FORD PRODUCTS

1979

5697

FASTENER
Door Trim Panel



UNIVERSAL

87655

CLIP-DOOR TRIM

(Also used for mounting
impact bumper covers)



- Impact resistant
black nylon

CHRYSLER

Omni, Horizon 1978-82

87067

CLIP-DOOR TRIM
PANEL MOULDING



Impact Resistant
White Nylon

CADILLAC
GM PRODUCTS

1977-81
1978-81

5736

FASTENER

Door Trim Panel and Cowl
Cardboard Insulating Panel



UNIVERSAL

87508

FASTENER-DOOR
& QUARTER TRIM
PANEL

- Steel construction

GENERAL MOTORS Cars

1979



DOOR TRIM FASTENERS



18669

FASTENER

Door Trim Panel

- Spring Steel with Corrosion Resistant Finish

PONTIAC

Bonneville, Grand Prix

1969-70

18670

PLUG

Door Trim Panel Fastener

- Material: Nylon

PONTIAC

Catalina 1968

Bonneville, Grand Prix 1968-70

OLDSMOBILE

F85 (exc. Cutlass) 1967

BUICK

Special, Skylark 1964-68

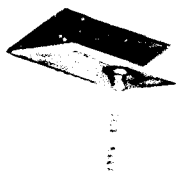

5737

TAB FASTENER

Door Trim Panel

- Corrosion Resistant Finish

GENERAL MOTORS

All

Most Years



23165

RETAINER**DOOR TRIM PAD**

- Extended lead for hard-to-reach places
- Material: Nylon

GENERAL MOTORS PRODUCTS

1971-74

22015

RETAINER DOOR TRIM

For most General Motors Cars

- Material: Nylon

GENERAL MOTORS

All

1971-72



23382

CLIP—**DOOR TRIM PANEL**

- Anti-Rust Coating
- Spring Steel

FORD PRODUCTS

1972-75

86930

RETAINER DOOR TRIM PAD

- Impact Resistant White Nylon

CHEVROLET AND GMC

Pick-Up Trucks

1977-81

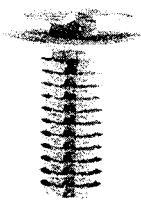

87559

CLIP**DOOR TRIM PANEL**





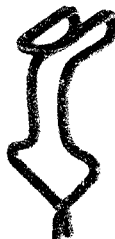

- Anti-Rust Coating
- Spring Steel







FORD PRODUCTS





1975-81



SPEED NUTS - BARREL TYPE

	13059	12205	11704	12163	9960	12195
P H O T O						
HOLE DIA.	3/32	3/16	3/16	7/64 & 15/64	5/32	5/32
STUD SIZE	1/32	3/32	3/32	3/64	1/8	1/8

	11264	12216	11702	12206	11265	16047
P H O T O						
HOLE DIA.	7/32	7/32	1/4	3/16	3/32	15/64
STUD SIZE	5/32	3/16	3/16	1/8	1/16	No. 10

<div style="text-align: center;">  <p>18697</p> <p>SPEED NUT – BARREL TYPE For attaching name plates and emblems.</p> <p>HOLE SIZE 3/16" STUD SIZE 5/32"</p> <p>UNIVERSAL</p> </div>	<div style="text-align: center;">  <p>87777</p> <p>BARREL NUT</p> <ul style="list-style-type: none"> ● For Attaching Nameplates ● Plastic – Black <p>HOLE SIZE 1/4" STUD SIZE 3/16"</p> <p>UNIVERSAL and CHRYSLER</p> </div>
<p>(ACTUAL SIZE PHOTOS)</p> <div style="text-align: center;">  <p>86007</p> <p>NUT – NAME PLATE AND EMBLEM RETAINING</p> <ul style="list-style-type: none"> ● Impact Resistant Nylon <p>HOLE SIZE 5/32" STUD SIZE 1/8"</p> <p>CHRYSLER and UNIVERSAL</p> </div>	<div style="text-align: center;">  <p>87841</p> <p>PUSHNUT-W/SEALER</p> <ul style="list-style-type: none"> ● Blind type ● Use for replacement of worn hole. <p>HOLE SIZE 1/4" STUD SIZE 3/16"</p> <p>CHRYSLER PRODUCTS 1978-80</p> </div>



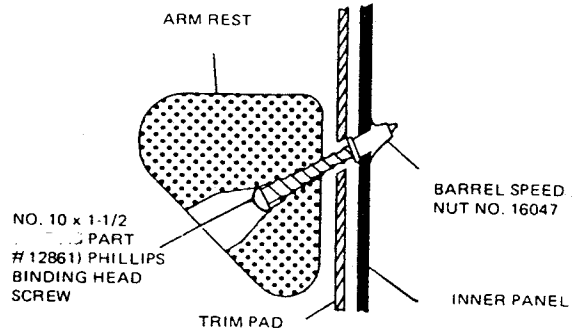

ARM REST FASTENERS

ARM REST SCREW & BARREL NUT





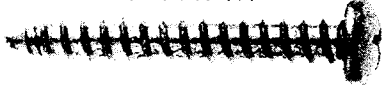
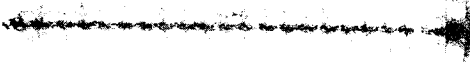
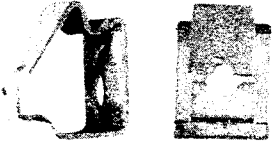



Many late model GM cars have problems keeping the arm rests secure on the door. The factory uses a 1/4 x 1-1/2" Binding Head Screw to hold the arm rest in place. The screws are driven directly into the panel without a holding nut. As the door is repeatedly opened and closed, the vibration and pulling causes the screws to strip out and the arm rest loosens and may fall off.



Drive the Barrel Speed Nut into the hole. Use a 10 x 1-1/2" Binding Head Screw - #12861 (Phillips Head) as the new Arm Rest Retaining Screw.

<p><u>BARREL SPEED NUT</u> 16047</p>  <p><u>BINDING SCREW HEAD</u> 12861</p> 	<p><u>DOOR & QUARTER ARMREST SCREWS</u> 13791</p> <ul style="list-style-type: none"> • Unichrome plated No. 14 x 1 3/4"  <p>No. 14 x 2 1/4" 9451</p> 
	<p>88024</p>  <p><u>CLIP - ARM REST RETAINING</u></p> <ul style="list-style-type: none"> • Spring Steel • For No. 14 Screws <p>FORD AND MERCURY Full Size 1979-80</p>
 <p>87719</p> <p><u>NUT - ARM REST</u></p> <ul style="list-style-type: none"> • Spring Steel • For No. 14 or 1/4" screws <p>FORD Mustang, Maverick, Pinto, Comet, Granada 1976-81</p>	 <p>87516</p> <p><u>NUT-ARM REST</u></p> <ul style="list-style-type: none"> • Spring Steel • For No. 8 Screws <p>FORD 1978-83</p>

DOOR LOCK CLIPS

 <p style="text-align: right;">9093</p> <p>CLIP Front Door Lock Control Link Retaining Right (4R) UNIVERSAL</p>	<p style="text-align: right;">87070</p>  <p>CLIP-DOOR LOCK General Usage ● Metal Construction GM PROD. AND UNIVERSAL 1959-Up</p>
 <p style="text-align: right;">9087</p> <p>CLIP Front Door Lock Control Link Retaining Left (4L) UNIVERSAL</p>	<p style="text-align: right;">23531</p>  <p>RETAINER Door Lock Remote Control Rod, Right Side ● Impact Resistant Nylon CHRYSLER 1971-74</p>
 <p style="text-align: right;">23535</p> <p>RETAINER Door Lock Remote Control Rod ● Impact Resistant Nylon FORD PRODUCTS 1965-74</p>	<p style="text-align: right;">23537</p>  <p>RETAINER Door Lock Remote Control Rod, Left Side ● Impact Resistant Nylon CHRYSLER 1971-74</p>
 <p style="text-align: right;">23536</p> <p>RETAINER Door Lock Remote Control Rod ● Impact Resistant Nylon FORD PRODUCTS 1975</p>	<p style="text-align: right;">13186</p>  <p>CLIP Rear Door Lock Remote Control Link 2 per car BUICK, All 1956-58 CHEVROLET, PONTIAC 1958</p>
<p style="text-align: right;">11920</p>  <p>CLIP Door Lock Control Link and Assembly Rod Retaining FORD Galaxie, Thunderbird 1965-66 Fairlane, Falcon 1966</p>	

DOOR AND WINDOW WEATHERSTRIP



18664

RETAINER

Door Opening Weatherstrip

- Material: Nylon

CHEVROLET

Passenger Sport Models 1967-70
Camaro & Chevelle 1965-70

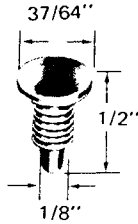

22481

CLIP - WINDOW WEATHERSTRIP

Black Nylon

FORD All Late Models
CHRYSLER All Late Models



11517

RETAINER

Door Opening Weatherstrip

- Material: Nylon

CHEVROLET

Station Wagon Tail Gate 1963-64
Chevy II & Chevelle

Roof Rail 1965-68

BUICK, All 1962-70

PONTIAC, All 1960-70

FORD, Most Models 1965-70

22704

CLIP - DOOR WEATHERSTRIP

GENERAL MOTORS PRODUCTS 1973











87843



SPACER-BACK WINDOW GLASS

FORD PRODUCTS 1979

LINKAGE CLIPS

<p>9086</p>  <p>2L</p>	<p>9092</p>  <p>2R</p>	<p>9087</p>  <p>4L</p>	<p>9093</p>  <p>4R</p>
<p>9095</p>  <p>7L</p>	<p>9094</p>  <p>7R</p>	<p>12435</p>  <p>AL</p>	<p>22716</p>  <p>AR</p>

124

BRASS FITTING

- Carburetor or Fuel Pump to Fuel Filter Line



6092

LOCKNUT

- Connecting Rod
- 3/8"-24



4171

LINKAGE RETAINER ASSORTMENT

- 9 different items
- 12 compartment plastic box



12232







HAIR PIN COTTER

- Carburetor
- Oil Tempered
- Annealed and Plated

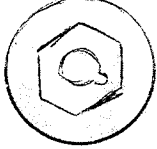



All Cars, All Years

PALNUTS - ANTI - CORROSION FINISH

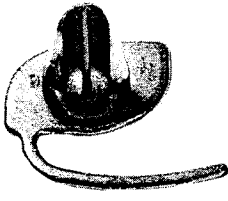

	DIMENSIONS	PHOTO		DIMENSIONS	PHOTO	
13429	5/16" Hex 17/32" Washer W/O Sealer	 1/8" STUD SELF-THREADING	10658	7/16 Hex 13/16 Dia.	 1/4" WASHER TYPE PLATED	
13637	5/16" Hex 17/32" W/Neoprene Sealer		86630	3/8" Hex 1/2" Washer	 10x24 THREAD	
18619	3/8" Hex 9/16" Washer Ford Emblems 1969	 5/32" STUD	TURTLE NECK TYPE			
13430	3/8" Hex 5/8" Washer w/o Sealer	 3/16" SELF-THREADING	18098	3/8" Hex 1/2" Washer	 1/8" STUD SELF-THREADING	
13638	3/8" Hex 5/8" Washer w/Neoprene Sealer		13431	7/16" Hex 11/16" Washer w/o Sealer	 1/4" STUD SELF-THREADING	
		13639	7/16" Hex 11/16" Washer w/Neoprene Sealer	10656		3/8" Hex 3/4" Washer
				85986	7/16" Hex 19/32" Washer	 1/4-20 THREAD PLATED

BODY SIDE MOULDING FASTENERS

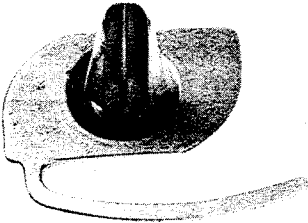
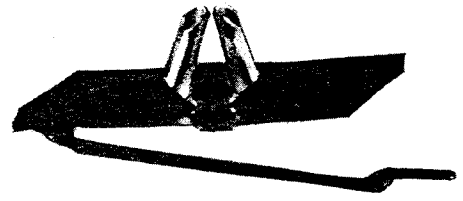
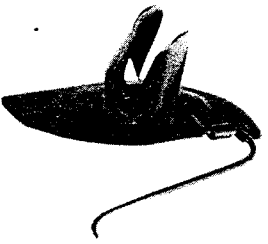
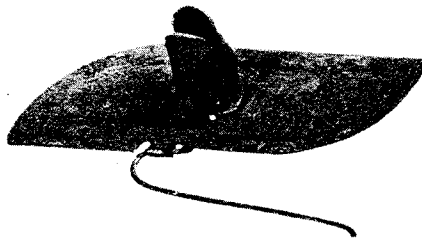
ACTUAL SIZE PHOTOS

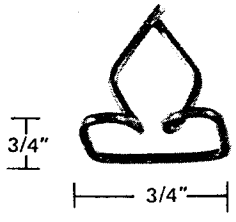
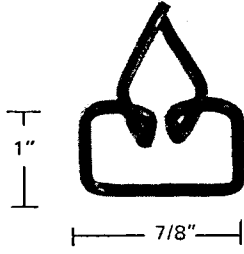
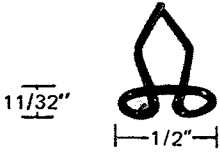
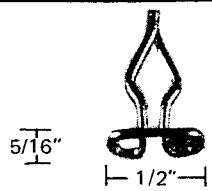
	APPLICATION AND PHOTO		APPLICATION AND PHOTO
11940	 For mouldings 3/8" to 11/16" wide		
17751	 For 5/16" dia Hole For mouldings 5/8" to 7/8" wide and 1/8" deep	11415	 For 5/16" Dia. Hole For mouldings 3/4" to 1-3/16" wide and 1/8" deep.
17752	 For 5/16" Dia. Hole For mouldings 1" to 1 1/4" wide and 1/4" deep.	12906	 For 3/8" Dia. Hole For mouldings 5/8" to 2" wide
14311	 For 5/16" to 11/32" Dia. Hole For mouldings 1/2" to 1 1/4" wide	14283	 For 5/16" Dia. Hole For mouldings 3/4" to 2" wide

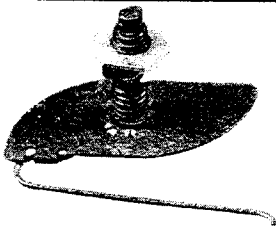
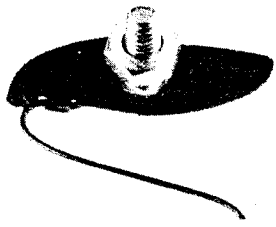
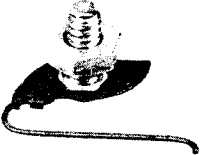
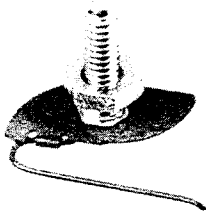
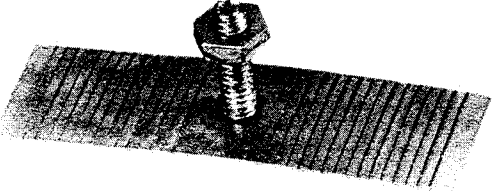
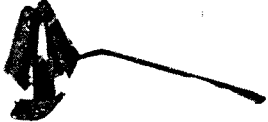
	16691		16693
	16689	WIRE RETAINERS <u>Fits Either Dimension Moulding</u>	
	16690		

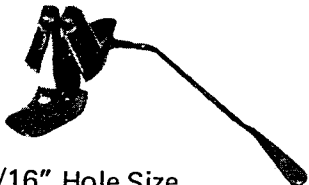
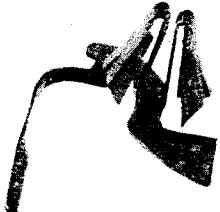





APPLICATION AND PHOTO		APPLICATION AND PHOTO	
 <p><u>T-BOLT AND NUT</u> No. 10-24 x 3/4" For mouldings 5/8" to 1 1/4" wide</p>	14292	 <p><u>T-BOLT AND NUT</u> No. 10-24 x 1/2" For mouldings 3/8" to 7/8" wide</p>	12118
 <p><u>T-BOLT AND NUT</u> No. 10-24 x 1/2" For mouldings 3/8" to 7/8" wide</p>	13000	 <p><u>T-BOLT AND NUT</u> No. 10-24 x 3/4" For mouldings 1/2" to 1" wide</p>	12555
 <p>Plate notched to permit breaking off to desired size with pliers.</p> <p><u>T-BOLT AND NUT</u> No. 10-24 x 3/4" For mouldings 1/2" to 2 1/2" wide</p>	7783		
APPLICATION & PHOTO		APPLICATION & PHOTO	
 <p>Retainer with Sealer For 5/16" Hole Size Fits mouldings 5/16" to 9/16" wide</p>	18683	 <p>For 5/16" Hole Size Fits mouldings 3/8" to 5/8"</p>	18978
 <p>For 5/16" Hole Size Fits mouldings 3/8" to 3/4" wide</p>	18687	 <p>For 5/16" Hole Size Fits mouldings 1/2" to 1" wide</p>	18684

REVEAL MOULDING CLIPS







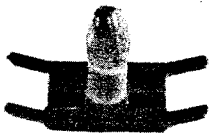
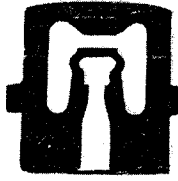

ANTI-CORROSION FINISH

ACTUAL SIZE PHOTOS

STUD MOUNTING TYPE

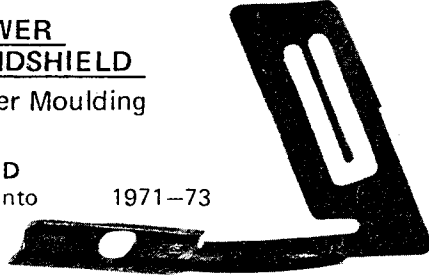

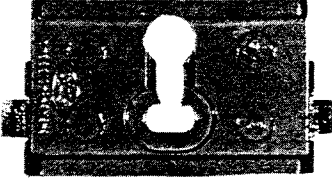
APPLICATION AND PHOTO		ACTUAL SIZE PHOTOS	APPLICATION AND PHOTO	
 WINDSHIELD REVEAL CHEVROLET, Chevelle 1968 PONTIAC, Tempest 1968 OLDSMOBILE, F85 1968 BUICK, Special 1968		18328	 UPPER REVEAL MOULDING WINDSHIELD & REAR WINDOW CHEVROLET Chevelle, Chevy II 1968 PONTIAC Tempest 1968 OLDSMOBILE, F85 1968 BUICK, Special 1968	
			 WINDSHIELDS & REAR WINDOW ● Station Wagon Qtr. Windows GM 1964-66	
			 WINDSHIELD REVEAL LOWER MOULDING GM PRODUCTS 1979-80	
18757	 REAR WINDOW REVEAL CHEVROLET 1969-70 Sport Coupe w/Vinyl top		 BELT MOULDING CADILLAC with vinyl tops 1969-71	
5949	 REVEAL MOULDING GM Sport Models w/Vinyl tops 1966-68			

FORD MOULDING FASTENERS

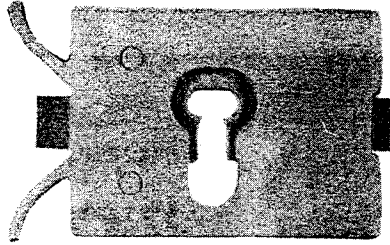
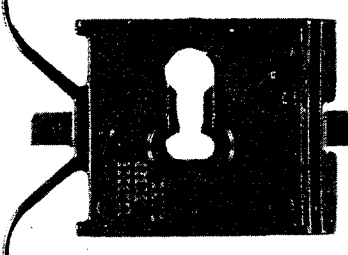
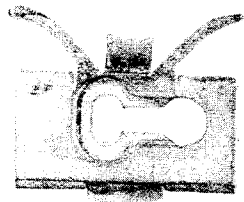

 <p style="text-align: center;">Yellow VINYL ROOF BELT MOULDING FORD 1980</p>	87925	 <p style="text-align: center;">WINDSHIELD REVEAL MOULDING FORD Maverick 1975 LINCOLN-MERCURY Cougar 1975</p>	23319
 <p style="text-align: center;">Black WINDSHIELD MOULDING CLIP FORD 1979</p>	88212	<p style="text-align: center;">REVEAL MOULDING</p> <p>Windshield & Back Glass</p>  <p>FORD , Maverick 1969-71 Pinto 1971</p>	22044
 <p style="text-align: center;">White VINYL ROOF BELT MOULDING FORD 1980</p>	87929	<p style="text-align: center;">LOWER WINDSHIELD</p> <p>Outer Moulding</p>  <p>FORD Pinto 1971-73</p>	<p style="text-align: center;">22876 Right Hand</p> <p style="text-align: center;">22877 Left Hand</p>
<p>DOOR MLDG. FRONT</p>  <p>FORD 1969</p>	18347	<p style="text-align: center;">REVEAL MOULDING</p> <p>Windshield Rear Window</p>  <p>FORD PROD. 1967</p>	9133
 <p style="text-align: center;">FORD, All 1969</p>	18327	<p style="text-align: center;">REVEAL MOULDING</p> <p>Rear Window</p>  <p>FORD PRODUCTS 1965-66</p>	11939

CHRYSLER MOULDING FASTENERS

APPLICATION AND PHOTO		APPLICATION AND PHOTO	
23168	 <u>FRONT, REAR DOOR, & QUARTER MOULDINGS</u> CHRYSLER PRODUCTS 1972-75	23420	 <u>BODY SIDE</u> CHRYSLER PRODUCTS 1975
87935	 <u>REAR DOOR LOWER MOULDING</u> CHRYSLER PRODUCTS 1980	23167	 <u>BODY SIDE</u> CHRYSLER PROD. 1971-74

	23171
<u>QUARTER WINDOW REVEAL MOULDING</u> Windshield & Back Glass Reveal Mldg. CHRYSLER PROD. 1974	
	22053
<u>REAR WINDOW REVEAL MLDG.</u> PLYMOUTH, Barracuda 1969-71	

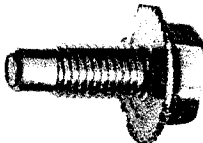
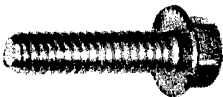
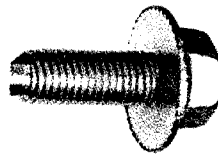
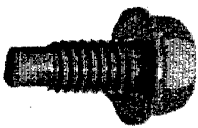
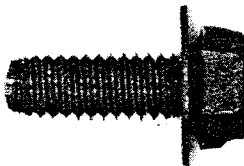
BODY BOLTS & SCREWS

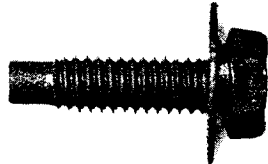
<p>12791</p>  <p>1/4-20 x 3/4 Serrated Washer Face</p>	<p>12518</p>  <p>5/16-24 x 3/4 13/16 Serrated Washer Face</p>
<p>12792</p>  <p>1/4-20 x 1 Serrated Washer Face</p>	<p>12550</p>  <p>5/16-24 x 1 11/16 Serrated Washer Face Special Dog Point</p>
<p>11475</p>  <p>5/16-18 x 3/4 11/16 Serrated Washer Face Special Dog Point</p>	<p>18365</p>  <p>3/8-16 x 1 Serrated Washer Face Special Dog Point Black Finish</p>
<p>18350</p>  <p>5/16-12 x 7/8 Serrated Washer Face AB Thread Type Black Finish</p>	<p>18398</p>  <p>5/16-18 x 1 Serrated Washer Face Special Dog Point Black Finish</p>

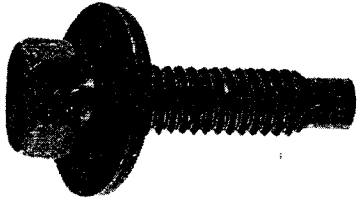
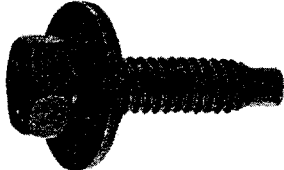
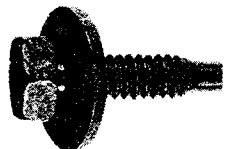
<p>87308</p> <ul style="list-style-type: none"> • 3/8-16 x 1 1/2" w/1" washer 
<p>87309</p> <ul style="list-style-type: none"> • 5/16-18x1-3/16" w/7/8" washer 
<p>87311</p> <ul style="list-style-type: none"> • 1/4-20x15/16" w/3/4" washer 

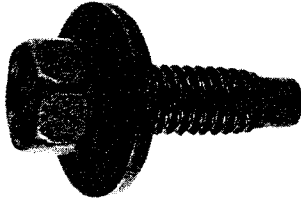
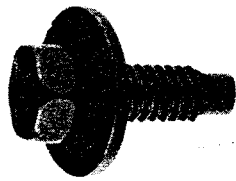
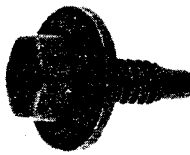
<p>87313</p> <ul style="list-style-type: none"> • 3/8-16x1-3/16" w/ 1" washer 
<p>87310</p> <ul style="list-style-type: none"> • 5/16-18x15/16" w/ 7/8" washer 
<p>87312</p> <ul style="list-style-type: none"> • 1/4-20x3/4" w/ 3/4" washer 

BODY ATTACHING PARTS

OPENING
.025 to .150

18387

NUT – Extruded "U" Type
Thread 1/4–20
G. M. AND UNIVERSAL

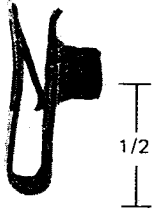

OPENING
.050 to .200

18391

NUT – Extruded "U" Type
Thread 3/8–16
G. M. AND UNIVERSAL

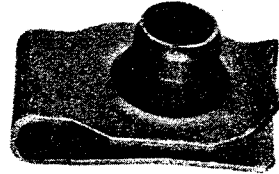
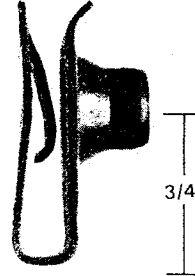

OPENING
.025 to .150

18388

NUT – Extruded "U" Type
Thread 1/4–20
G. M. AND UNIVERSAL

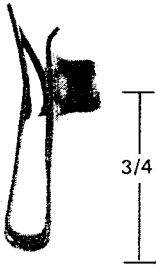

OPENING
.050 to .200

18392

NUT – Extruded "U" Type
Thread 3/8–16
G. M. AND UNIVERSAL

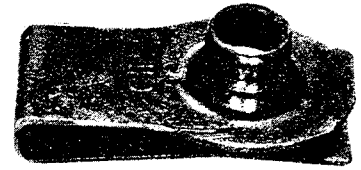
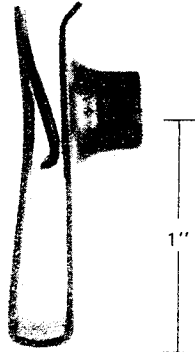

OPENING
.025 to .150

18389

NUT – Extruded "U" Type
Thread 5/16–18
G. M. AND UNIVERSAL

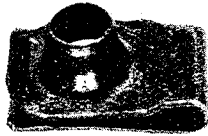
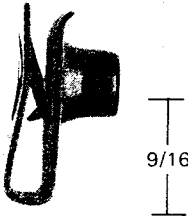

18395

NUT – Extruded "J" Type
Thread 3/8–16
Front End Assembly
G. M. AND UNIVERSAL

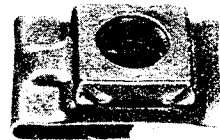
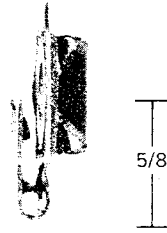

OPENING
.025 to .150

18390

NUT – Extruded "U" Type
Thread 5/16–18
G. M. AND UNIVERSAL

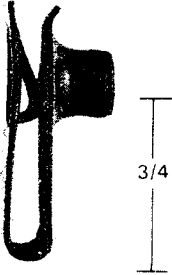

OPENING
.210 to .330

87504

NUT–Extruded "U" Type
Thread 1/4–20
For grilles in fiberglass
Sections–7/32" to 15/64"
panel range
FORD PROD. 1977-Up

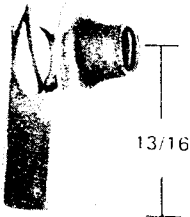

NUT - EXTRUDED "U" TYPE

● Used For Sheet Metal and Front End Assembly
on General Motor Cars - 1977-Up

● Blue Finish

6604

4mm
0.7 Thrd.



9.5mm

4mm

MM - 0.7
Metric Extruded
"U" Nut

86605

4mm
0.7 Thrd.



13.5mm

4mm

4mm - 0.7
Metric Extruded
"U" Nut

6606

5mm
0.8 Thrd.



15.8mm

4mm

MM - 0.8
Metric Extruded
"U" Nut

86607

6.3mm
1.0 Thrd.



13.5mm

4.5mm

6.3mm - 1.0
Metric Extruded
"U" Nut

86603

8mm
1.25 Thrd.



14.5mm

4mm

MM - 1.25
Metric Extruded
"U" Nut

86608

8mm
1.25 Thrd.



20.0mm

4.5mm

8mm - 1.25
Metric Extruded
"U" Nut

86602

10mm
1.5 Thrd.



19.0mm

6mm

10MM - 1.5
Metric Extruded
"U" Nut

86856

8mm
1.25 Thrd.



20mm

7mm

8mm - 1.25
Metric Extruded
"U" Nut

Bumper Strips
Bumper Guards

CHEVROLET,
CADILLAC
1978-Up

NUT RETAINER TYPE

11703

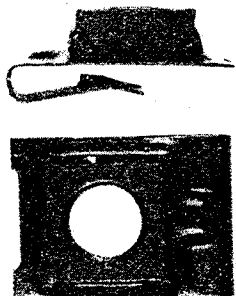

"J" Type
Rear Bumper Attachment
7/16-14 Thread Size

FORD
Thunderbird 1965-Up
MERCURY 1965-Up

11707

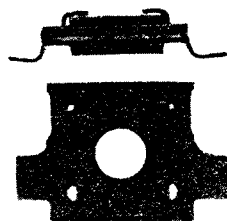

Clinch Type
Front End Sheet Metal
5/16-18 Thread Size

FORD
Falcon, Comet 1965-Up

WINDOW CRANK KNOBS

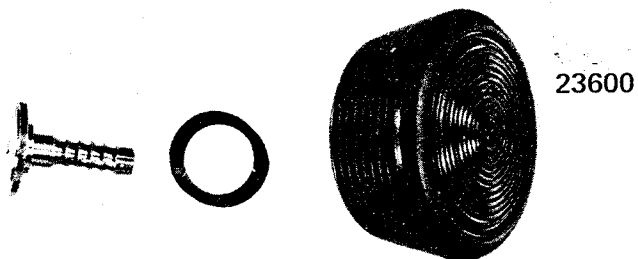

23600

KNOB KIT – WINDOW CRANK HANDLE

Contains: Black, Textured Nylon Knob, Push-On Retainer, and Washer.

Eliminates replacing complete handle.

O.E.M. SUPPLIES ASSEMBLY ONLY

CHEVROLET Trucks 1970-82



9866

KNOB

For 3/16" shaft dia.
Complete with set screw
Chrome-plated plastic

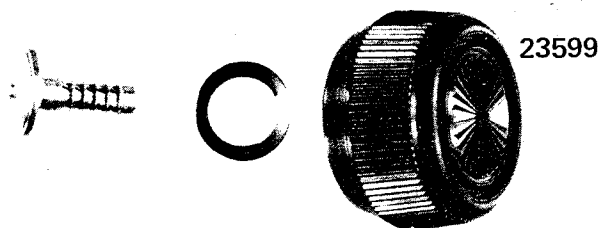

23599

KNOB KIT – WINDOW CRANK HANDLE

Contains: Black, Textured Nylon Knob, Push-On Retainer and Washer.

Eliminates replacing complete handle.

O.E.M. SUPPLIES ASSEMBLY ONLY

FORD TRUCKS 1970-82



11054

KIT – WINDOW RISER HANDLE KNOB

Black Plastic

ALL CARS AND TRUCKS All Years
NOT SUPPLIED BY CAR MFG.

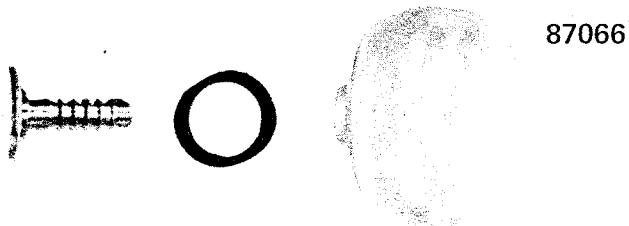

87066

KNOB REPAIR KIT – WINDOW CRANK HANDLE

Contains: Clear, Textured, Nylon Knob, Push-on Retainer and Washer

Eliminates replacing complete handle

FORD PROD. 1974-75

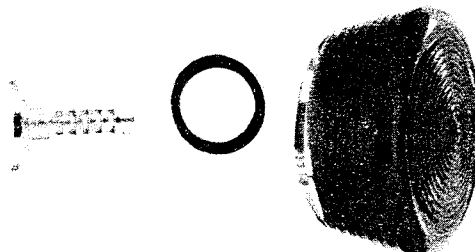

23610

KNOB KIT – WINDOW CRANK HANDLE

Contains: Textured, Nylon Knob with Positive-Hold Push-On Retainer.

Eliminates replacing complete handle.

O.E.M. SUPPLIES ASSEMBLY ONLY

CHEVROLET Pass. All 1970-82

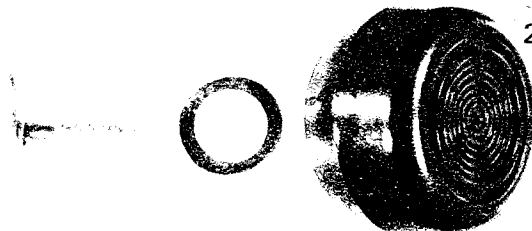

22309

C8AZ-6223352-A1A

KIT – WINDOW CRANK HANDLE

Kit includes Black Knob, Screw and Washer.

8571



**WHEEL OPENING MOULDING
SCREW
PHILLIPS HEAD SHEET
METAL SCREW**

Size: 8 x 3/8 Nickel Plated

87554

**SCREW - WHEEL
HOUSE MOULDING**

- No. 10 x 9/16"
- Self drilling
- Oversize
- Zinc Plated



UNIVERSAL All Cars

86757

CLIP

Wire Retaining
Harness - Nylon
13/16" Int. Diameter

UNIVERSAL



BUTTON PLUGS

For Covering Access Holes in Doors
and Body Panels

- Black Polyethelene
- Flush Head Type
- Universal Application
- Just Push On

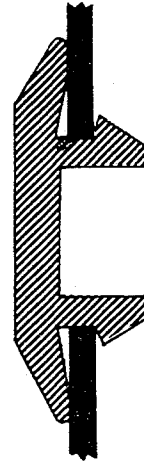

SIZE HOLE SIZE

	SIZE	HOLE SIZE
87641	3/8"	.370-.380
18321	1/2"	.480-.515
18322	15/16"	.922-.955

5745

5746

LOOM FASTENERS

Lamp Wiring
UNIVERSAL



SHORT

LONG



87837

CLIP-WIRE AND TUBING

- For 1/4" Holes
- Special lip to retain wiring.
- No need to thread entire length through clips. Slips on at hole.
- Black, flexible, impact resistant plastic.
- OEM style.



UNIVERSAL

CLIP

Wire and Tube Retaining

- For 1/4" Holes
- Opens to encircle wiring or tubing at any point; no need to "thread" entire length through clip. Slips on at hole.
- Black, flexible, impact resistant plastic

UNIVERSAL

86929



1/4" I.D.

86889



1/2" I.D.

86890



5/8" I.D.

86891



3/4" I.D.

FLAT HEAD DESIGN

ROUND HEAD DESIGN

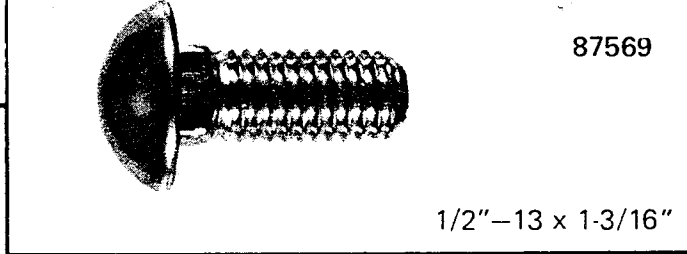
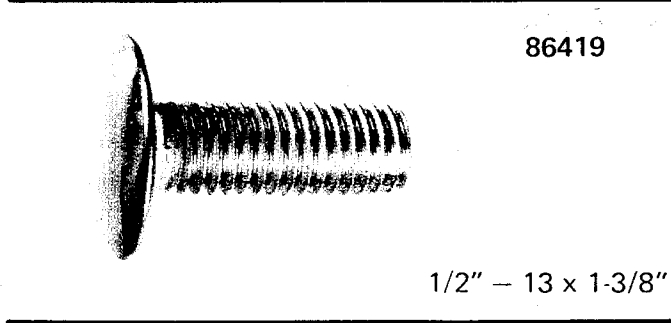
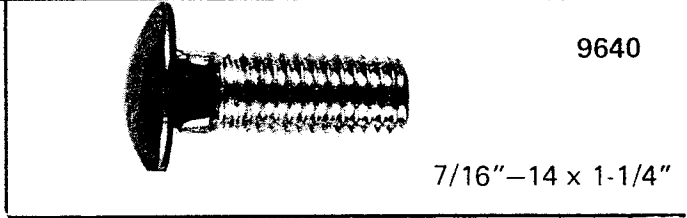
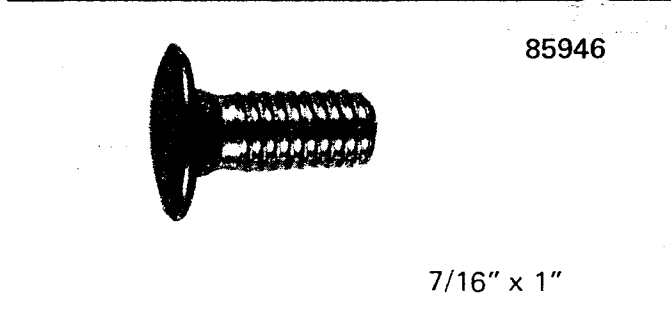
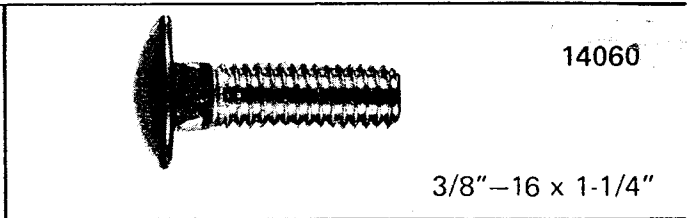
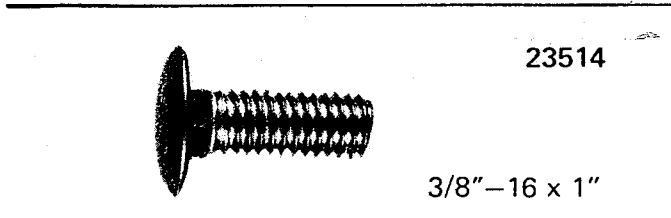

* Actual Size Photos

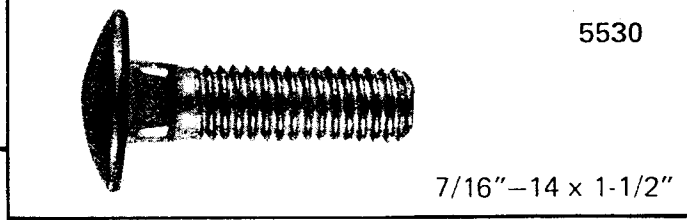

SEMI-ROUND HEAD TYPE

- Stainless Steel Caps

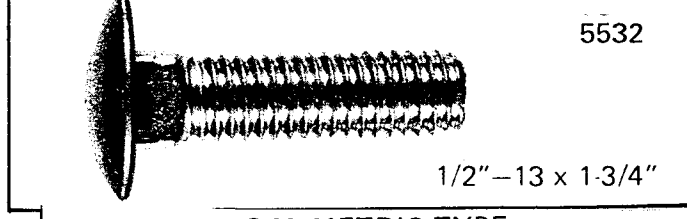
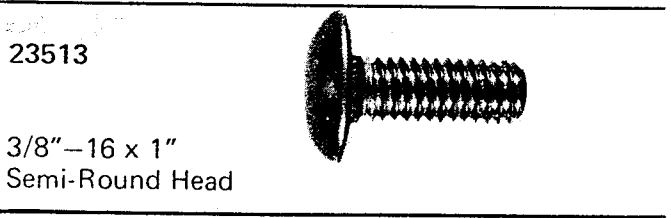
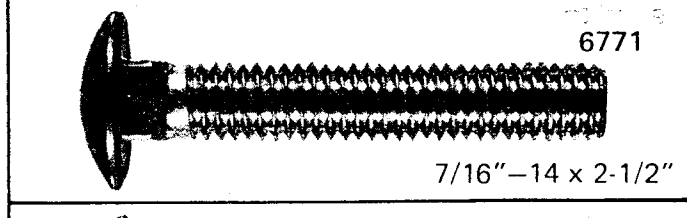





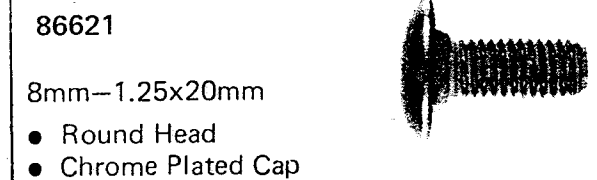
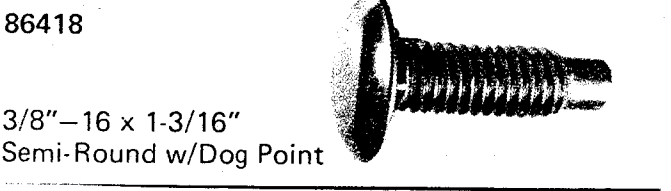
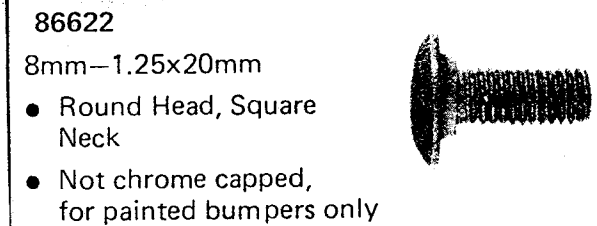
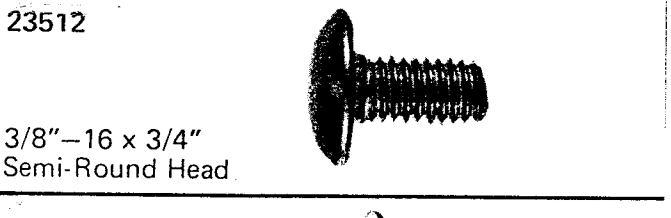

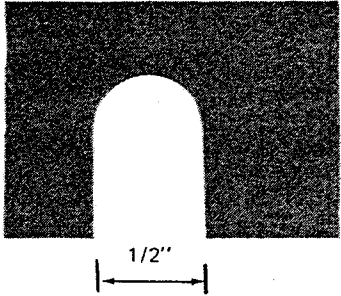

G.M. METRIC TYPE

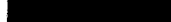
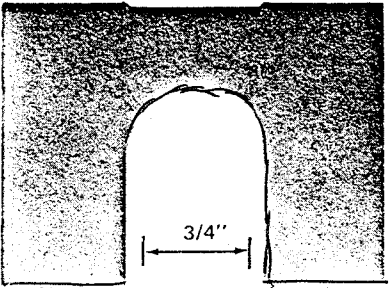
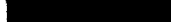
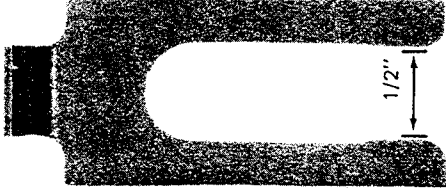
- Grade 9.8

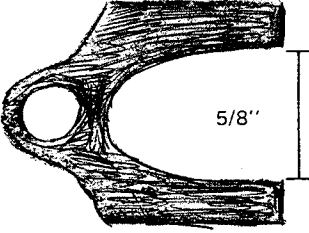

SHIMS

PHOTO	DESCRIPTION	THICKNESS	
 <p>1/2"</p>	<u>UNIVERSAL BODY SHIM</u>	 1/16"	9338
		 1/8"	9339
 <p>3/4"</p>	<u>UNIVERSAL BODY SHIM</u>	 1/8"	12142
 <p>1/2"</p>	<u>UNIVERSAL BODY SHIM</u>	 1/16"	22080
		 1/8"	22081
 <p>5/8"</p>	<u>UNIVERSAL SHIM</u> Ball Joint	 1/32"	16106
		 1/16"	16107
		 1/8"	16108

STOCK #	QUANTITY	PRICE									
<u>PAGE 7</u>											
			9093	1	1.00						
			9087	1	1.00						
<u>PAGE 1</u>			23535	1	1.00						
23412	29	6.00	23536	1	1.00						
86958	35	6.15	11920	1	1.00						
87518	41	6.35	87070	1	1.00	<u>PAGE 15</u>					
85992	22	6.50	23531	1	1.00	23168	14	4.75			
5730	12	7.05	23537	1	1.00	87935	6	5.75			
7029	25	6.00	13186	2	2.00	23171	12	4.25			
<u>PAGE 2</u>						22053	20	5.50			
89239	15	7.10	<u>PAGE 8</u>			23420	6	4.50			
89240	15	7.10	18664	10	4.00	23167	12	7.15	<u>PAGE 22</u>		
89241	15	7.10	11517	10	4.00	<u>PAGE 16</u>			9338	29	6.09
89243	15	7.10	22704	36	6.50	12791	34	6.15	9339	18	7.05
89247	15	7.10	22481	11	4.50	12792	33	6.25	12142	15	7.10
7748	150	6.00	87843	12	4.75	11475	16	6.25	22080	47	6.75
7749	150	6.00	<u>PAGE 9</u>			18350	21	6.25	22081	27	6.75
89249	10	6.50	9086	2	2.00	87308	10	6.25	16106	20	6.00
89248	5	5.50	9092	2	2.00	87309	14	6.50	16107	20	6.50
22878	16	5.75	9087	2	2.00	87311	17	6.00	16108	20	6.50
13740	37	6.55	9093	2	2.00	12518	15	6.05			
86581	18	5.00	9095	2	2.00	12550	21	6.50			
13159	31	5.50	9094	2	2.00	18365	16	6.45			
13739	30	5.75	12435	2	2.00	18398	14	6.45			
86582	16	5.75	22716	2	2.00	87313	11	6.50			
15320	18	6.25	8124	1	.50	87310	15	6.05			
<u>PAGE 3</u>			6092	4	1.00	87312	17	6.35			
22689	36	8.00	14171	1	20.00	<u>PAGE 17</u>					
5697	33	5.75	12232	10	4.00	18387	10	5.90			
87067	22	6.50	<u>PAGE 10</u>			18388	10	6.10			
87508	19	6.15	13429	20	4.50	18389	9	6.10			
87515	9	6.35	13637	19	6.50	18390	8	6.15			
87655	37	6.70	18619	36	4.75	18391	5	6.35			
5736	25	6.30	13430	25	4.50	18392	4	5.75			
			13638	17	6.25	18395	7	6.00			
<u>PAGE 4</u>			13431	20	4.25	87504	10	6.35			
18669	28	6.00	13639	16	6.25	<u>PAGE 18</u>					
5737	26	6.00	10656	29	4.75	86604	33	6.75			
22015	35	6.30	86986	30	4.75	86605	28	6.75			
86930	15	5.75	10658	17	4.50	86606	22	6.60			
18670	27	6.05	86630	18	7.50	86607	20	6.60			
23165	29	5.70	18098	30	5.00	86603	22	6.60			
23382	37	5.50	<u>PAGE 11</u>			86608	18	6.75			
87559	27	6.15	11940	36	6.40	86602	10	6.50			
<u>PAGE 5</u>			17751	36	7.00	86856	11	6.00			
13059	10	5.50	17752	14	6.25	11703	14	6.25			
12205	10	5.25	14311	12	8.75	11707	15	6.30			
11704	10	5.25	11415	18	6.25	<u>PAGE 19</u>					
12163	10	5.25	12906	6	6.45	23600	2	6.00			
9960	10	5.25	14283	4	6.05	23599	2	6.00			
12195	10	5.25	16691	25	6.55	87066	2	6.00			
11264	10	5.25	16689	28	6.55	9866	2	4.00			
12216	10	5.25	16690	27	6.55	11054	2	4.00			
11702	10	5.25	16693	21	6.55	23610	2	6.00			
12206	10	5.25	<u>PAGE 12</u>			22309	2	6.00			
11265	10	5.25	14292	12	6.05	<u>PAGE 20</u>					
16047	10	5.25	13000	10	6.05	18571	40	4.00			
18697	19	5.20	7783	21	7.15	86757	12	7.00			
87777	36	5.20	18683	15	6.40	5745	40	10.00			
86007	32	6.05	18687	15	6.40	5746	40	11.00			
87841	21	6.05	12118	13	6.40	87554	10	5.75			
<u>PAGE 6</u>			12555	13	6.40	87641	20	4.00			
16047	10	5.25	18978	28	6.40	18321	20	4.25			
12861	35	5.25	18684	12	6.15	18322	20	6.00			
87719	22	6.05	<u>PAGE 13</u>			87837	24	5.35			
13791	17	6.25	18328	20	4.25	86929	36	6.60			
9451	14	6.25	18757	15	5.25	86889	36	7.00			
88024	15	5.95	5949	15	4.55	86890	36	7.25			
87516	12	5.95	18086	13	4.55	86891	36	7.40			
			11848	15	4.55	<u>PAGE 21</u>					
			88282	20	6.30	23514	10	6.00			
			22052	20	4.55	85946	11	6.00			
			<u>PAGE 14</u>			86419	8	6.00			
			87925	10	6.25	23513	10	6.50			
			88212	8	4.75	23512	12	6.50			
			87929	9	4.75	86418	12	6.50			
			18347	12	4.95	14060	12	6.50			
			18327	9	5.00	9640	9	6.75			
			23319	8	5.00	87569	9	6.60			
			22044	10	6.00	5530	8	6.70			
			22876	5	4.25	6771	6	6.05			
			22877	5	4.25	5532	6	6.05			
			9133	12	4.75	86622	28	7.25			
			11939	10	6.75	86621	14	6.25			

